

NO.	PART	MATERIAL
1	BODY	UPVC
2	DISC	POLYPROPYLENE
3	SEAT	EPDM
4	STEM	410 STAINLESS STEEL
5	O-RING 1	EPDM
6	O-RING 2	EPDM
7	INSERTED NUT	410 STAINLESS STEEL
8	LARGE HANDLE	ABS
9	SMALL HANDLE	ABS
10	SPRING LOCK	ABS
11	HANDLE INSERT	STAINLESS STEEL
12	HANDLE LEVER	304 STAINLESS STEEL
13	SPRING	304 STAINLESS STEEL
14	SPRING PIN 1	304 STAINLESS STEEL
15	SPRING PIN 2	304 STAINLESS STEEL
16	WASHER 1	304 STAINLESS STEEL
17	LOCKING PLATE	304 STAINLESS STEEL
18	GEAR SEAT	POLYPROPYLENE
19	WASHER 2	304 STAINLESS STEEL
20	BOLT	304 STAINLESS STEEL
21	NUT	UPVC
22	INSERT NUT	410 STAINLESS STEEL
23	SCALE	304 STAINLESS STEEL
24	RIVET	STAINLESS STEEL

SIZE	2"	2-1/2"	3"	4"	6"	8"
A	6.50	7.25	7.87	9.01	11.22	13.50
B	4.74	5.49	6.00	7.50	9.51	11.75
C	2.22	2.76	3.11	4.05	5.94	7.87
D	4.13	4.72	4.84	5.31	6.65	7.87
E	7.99	7.99	7.99	10.00	11.97	11.97
F	9.68	10.47	10.87	12.52	15.94	18.35
G	4.05	4.45	4.53	5.31	6.97	8.27
H	1.65	1.81	1.81	2.20	2.79	3.42
I	1.38	1.46	1.46	1.85	2.44	2.68
J	3.66	3.70	3.70	3.94	3.94	4.72
K	.75	.75	.75	.75	.87	.91

Model S-650

PVC Butterfly Valve

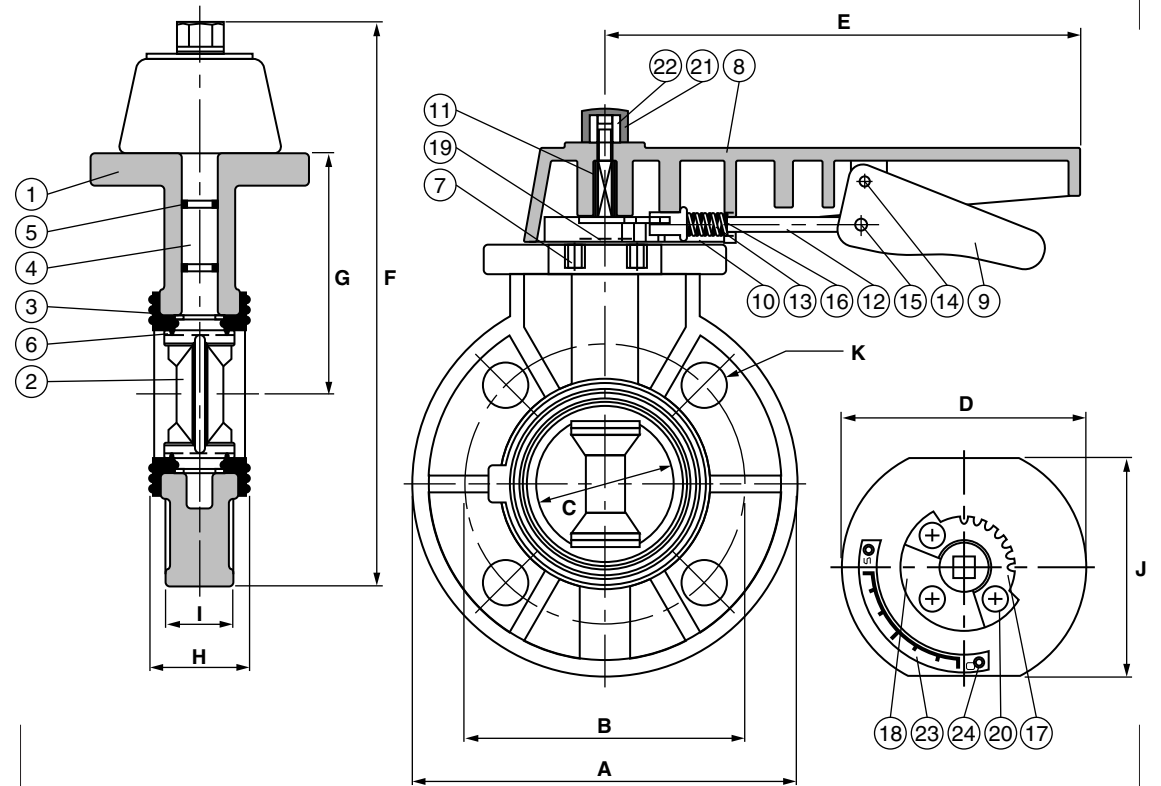

- NOTES:
- PRESSURE RATING: 150 WOG AT 73°F
- TEST PRESSURE: 225 WOG