

SUBMITTAL SHEET

JOB NAME	ITEM TAG
JOB LOCATION	PART NUMBER
CONTRACTOR	DATE
ENGINEER APPROVAL	DATE

NICKEL-PLATED BALL-TYPE HOSE BIBB WITH LEVER HANDLE

T-537CP

Durable forged brass construction with nickel plating.

The positive-shutoff ball-and-seat design is a more durable alternative to traditional stop-type valve designs

Hybrid o-ring and stem packing design.

Smooth quarter-turn operation

Angled body and hose connection reduces the likelihood of hose kinking.

Ideal for all residential and commercial hose bibb requirements.

Available in sizes: 1/2" MNPT/Sweat x 3/4" GHT

Working Pressure, Non-Shock (PSI):

Cold Working Pressure (CWP): 200 psi

Saturated Steam (WSP): Not suitable for steam service



Pictured:
T-537CP

MATERIAL SPECIFICATION

PART	MATERIAL
1 Body	Nickel-plated forged brass
2 Seats	PTFE
3 Ball	Chrome-plated forged brass
4 Stem O-Ring	NBR (Buna-N)
5 Stem Packing	PTFE
6 Stem	Forged brass
7 Nut	Plated steel
8 Lock Washer	Plated steel
9 Handle	Plated steel
10 Packing Nut	Chrome plated forged brass

DIMENSIONS - INCH

Size	A	B	C	D
1/2"	3.42	1.73	3.46	0.4

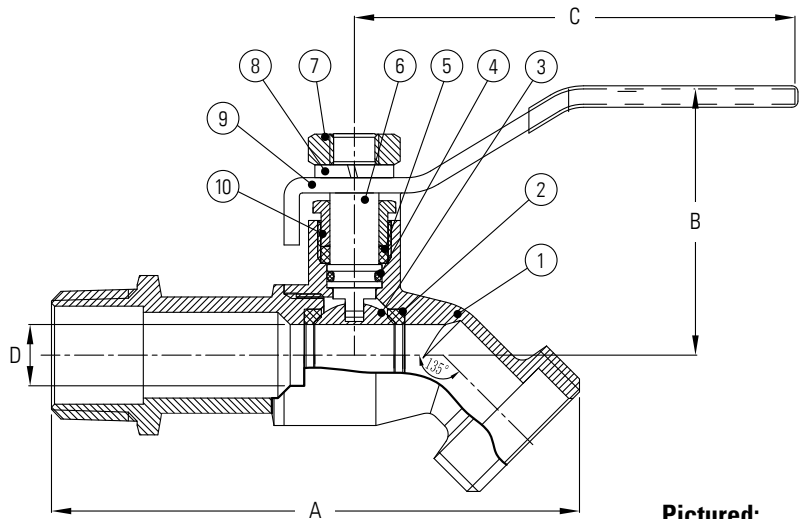

Pictured:
T-537CP Cut-away

Standards:

ANSI/ASME B16.18: Cast pressure alloy solder-joint pressure fittings.

ANSI/ASME B1.20.1: Pipe threads, general purpose, Inch.

ANSI/ASME B1.20.7: Hose coupling screw threads, Inch.